

by



iNOKiM

mini

User's Manual

iNOKiM

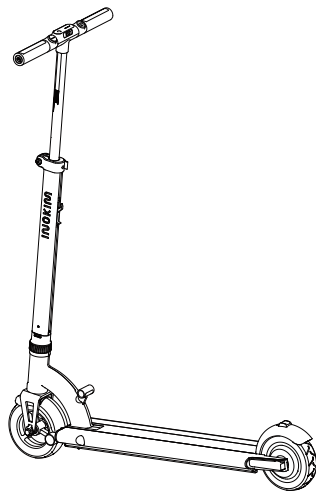

Product Schematic

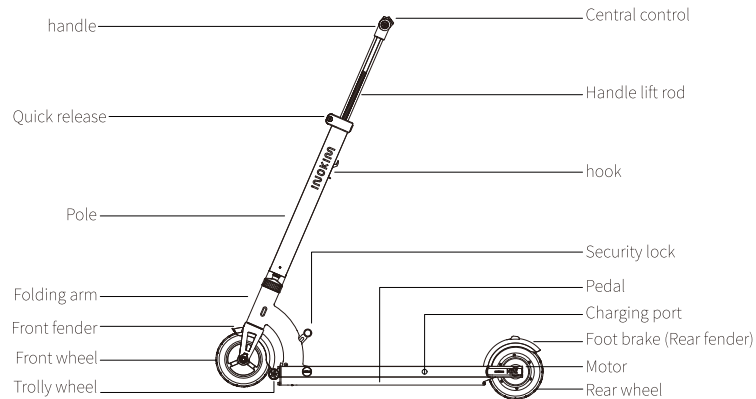

Accessories List

Handle sleeve*2, Charger, Warranty Card, Multi-functional tool, Small wrench, Inflator.

Installation Steps

Product Parameters

A. Pull the hook forward to extend the pole to the maximum angle.

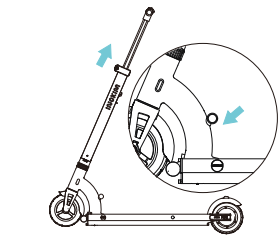
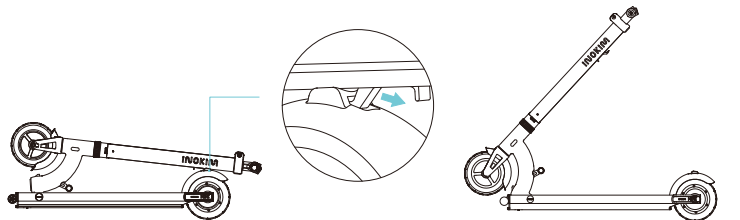

B. Pull up the pole to the appropriate height and depress the security lock.

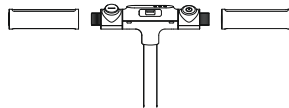

C. Turn the handlebar to the hand lever in the direction of the thread.

Model	Mini Miracle	Mini Force
Size	Unfolded Length * width * height: 91cm*38.4cm*113.5cm	
	Fold Length * width * height: 87cm*38.4cm*30cm	
Weight (with battery)	8.5kg	8.7kg
Finish	Automotive grade paint + electrostatic spray + Anodized Anodize treatment	
Suggested load	Less than 95kg	
Main material	AL6061/6063 Aircraft aluminum	
Battery	21.6V7.8AH 18650Cell	36V5.8AH 18650Cell
Maximum speed	17km/h	20km/h
Range	15~20km(Full power 75kg 15km/h 25°C Flat road condition 20km range)	
Charging time	4h	3h
Motor Power	200W	250W
Tire specification	6 inch pneumatic tire + 6 inch honeycomb rubber tire	
USB output	5V 1A	
Brake	EABS linear electronic brake + physical step on the brake of rear wheel	
Parameters of charger	Rated input voltage: 100V-240V	Rated input voltage: 100V-240V
	Rated output voltage: 25.2V 2A	Rated output voltage: 42V 2A

Routine Maintenance

- damage caused is not within warranty;
- Avoid keeping the battery empty for a long time or overcharged;
 - Please draw the charger cord when installing or replacing the battery or any maintenance of Inokim.
 - Prohibit dismantling and placing any items into the battery, the behavior may cause a great risk of electric shock, injury, burns and fire;
 - Any attempt to disassemble the battery will damage the battery and release the toxic substances;
 - You can only use the charger provided by Inokim for charging;
 - Transport the battery of INOKiM according to the relevant laws and regulations of the country or region;
 - Do not use the battery under the following circumstances: battery damage, smell strange or overheating, or there is scene of leakage;
 - Do not place the battery in an environment above 50 ° C or below -20 ° C. The performance of the battery will be decreased when the temperature is below 0 ° C.

Check if the screws are loose

* All screws in Inokim have passed anti loosening treatment, and they are not easy to loose. Considering safety, please check the components such as quick release, hub, battery pack, fender, etc., check the components by hand or tool to see if the components are loose or abnormal. If you feel abnormal, please check the relevant screws and use the tool to fasten them.

Check the pneumatic tire regularly

* Please check the condition of the front tire regularly. If you find your tyre is not sufficiently inflated, please use the pump to inflate the tires to keep the tire pressure stability of the front tire, to improve the driving comfort and stability.

Central Control Panel (Miracle)

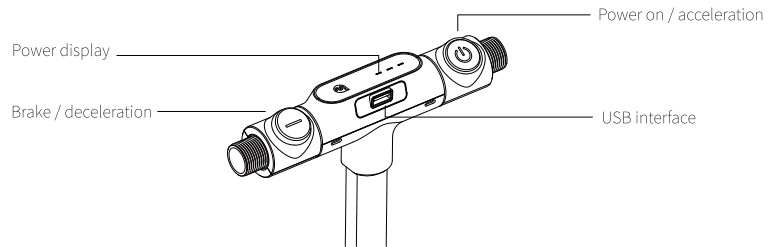

Operation Method (Miracle)

Basic operation

Power on: Long press for 3 seconds

Work of waking up motor: Long press + pedal (speed up the scooter to a Certain speed)

Acceleration: Long press + pedal

Brake: / step on the rear fender

Shutdown: Double click

Warm tips

Pedal: Hold the handle with both hands, pedal with one foot and the other keeps the vehicle balanced.

Brakes: mini brake is electronic brakes, the deeper brake button press, the greater the braking force is.

Cruise: When the motor is awakened and enters into work, the motor will be in the default speed cruise mode. (When using brake, the cruise model will be cancelled. Press the power button to return to cruise mode.)

Note: If you want to glide after full stop, you need to wake the motor up again , suggest to use the rear mudguard brake when you need restore the speed in a short time.

Central Control Panel (Force)

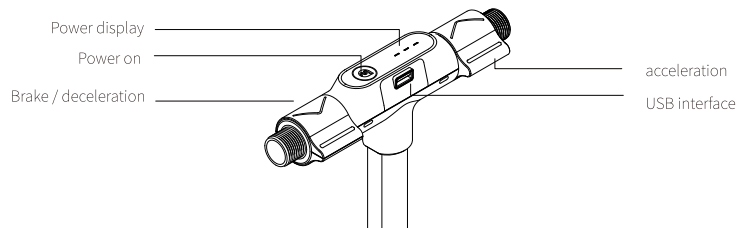

Operation Method (Force)

Basic operation

Power on:  Long press for 3 seconds

Toggle mode:  long press

Accelerate: right click

Brake: left finger dial/ step on the rear fender

Shutdown:  Double click

Warm tips

Green light is for the energy-saving mode, the maximum speed is 12KM / h.

Blue light is for the performance mode, the maximum speed is 20 KM / h.

Note: When starting, hold the handle with both hands, pedal with one foot and the other foot keeps the vehicle balanced, hold down the right finger with feet naturally standing on the feet.

Routine Maintenance

Cleaning and storage

- 1、 It is advisable to clean the Inokim in time after using to ensure that Inokim is in good condition;
- 2、 You can use a soft cloth with a small amount of water to wipe Inokim's body;
- 3、 You can use a rag to wipe Inokim's tire and fender, banning the rinse of rear wheel (the rear wheel is motor). Wipe them with a dry cloth as soon as possible, and place it in a ventilated place to avoid corrosion of metal parts;
- 4、 When not in use, please keep Inokim in a dry and cool environment. Avoid outdoor storage in the long time.
 - * When cleaning Inokim, make sure Inokim is off and the charger has been unplugged and fastened the charging cover! To avoid electric shock or vehicle malfunction;
 - * It is strictly forbidden to rinse the Inokim directly with the high-pressure water gun or to soak the vehicle in the water when cleaning. Above measures may cause the accumulation of water vapor or water flowing into the body, resulting in an unrecoverable failure;
 - * Do not use alcohol, gasoline, kerosene, acetone or other corrosive chemical solvents to clean the body, otherwise it will lead to the damage of the appearance and internal structure.

Maintenance of battery pack and its usage specification

- 1、 Do not run the motor when charging;
- 2、 The display on the panel can only indicate the approximate power range. It is for reference only and it can't accurately display the power;
- 3、 Avoid contact with the material leaking out of the battery, and do not let the minor contact with the battery;
- 4、 If using the battery is not in accordance with the instructions or unauthorized removal of the battery, the

Safety Tips

Civilized / safe driving precautions

1. Before driving Inokim, please comply with local traffic laws and regulations and civilized driving as well as pay attention to the surrounding people and things reducing the chance of accidents;
2. When driving Inokim, please prevent over speed, maintain a certain safe distance with pedestrians and other driving vehicles, and always pay attention to the use of brake function;
3. Develop good riding habits to avoid rapid acceleration start and emergency deceleration brake;
4. When driving among a large number of pedestrian vehicles, please be sure to slow down or get off to pull forwards;
5. When stay out with other Inokim users, please keep the appropriate safe distance, to avoid danger and obstacles. Unless there is enough space for pedestrians, do not run side by side;
6. Do not park Inokim in areas that would obstruct pedestrians or areas that are not allowed to park;
7. Do not drive in bad vision, if decide to use, please reduce the speed, be vigilant, and add external lights to ensure a good driving vision;
8. keep the body relaxed when driving, such as knees and elbows slightly bent and upright forward.

Active safety protection measures

1. Do not let others use your Inokim unless the person has read the manual carefully;
2. uring the driving process, wear a helmet and elbow guard knee which have passed the relevant quality verification, the helmet wearing must meet the head type, equipped with hatband and can protect the back of the head. The driver can wear protective equipment such as gloves, eyepiece, and waist according to the situation and experience;
3. Do not drive if you are not feeling well or can not follow the instructions in this manual.
4. Check the vehicle every time when you drive Inokim, and if you find any loose or damage, do not drive before the fault is removed;

Folding Method

A. Hold the handle with both hands, hook up the safety lock with foot.

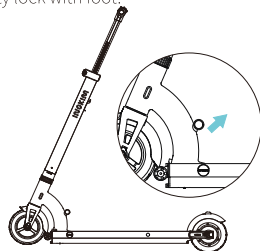

B. Hold the handle with both hands and kick the safety lock with your foot.

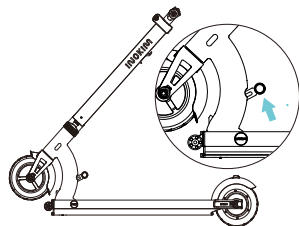

C. Put the pole down to interlock with the rear fender.



Hook



The rear fender



Put the hook into the slot

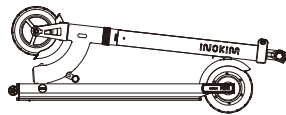

Standing And Dragging

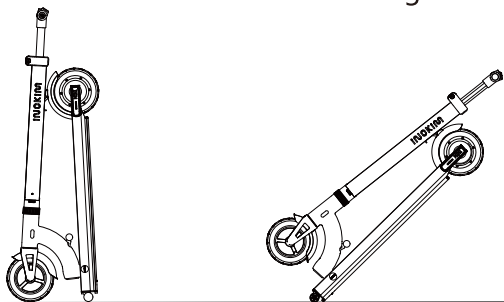

Charge

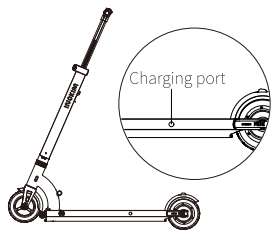

Charging



Finished charging

Safety Tips

The matter must comply with

- 1、 Understand and strictly comply with local traffic regulations;
- 2、 Wear safety helmets and protective gears which have been through relevant quality verification before driving;
- 3、 Check the basic situation of Inokim, if outer parts are loose, drop or broken, please contact the official customer service;
- 4、 Please make sure that your body in good condition before driving. Do not drive if drinking, taking sedatives or other psychiatric drugs within 6 hours.

Strict prohibitions

- 1、 Prohibit using in area prohibited to enter according to the law of the country / region and the relevant management units;
- 2、 Prohibit one hand or both hands to leave the handle;
- 3、 Avoid driving in the risky area where do not meet the requirements of the usage;
- 4、 Prohibit driving into the motorway. Non-motorized lanes are not allowed to enter such vehicles in some countries and regions. Please subject to local laws and regulations;
- 5、 Prohibit manned driving, especially prohibit holding or carrying infants or children;
- 6、 Prohibit minors under age of 12 years and adults over age of 65 years;
- 7、 Prohibit pregnant women, alcoholics, mental patients, heart and brain disease patients and limited mobility and other personnel to drive;
- 8、 Prohibit dangerous behaviors such as driving when making call;
- 9、 Prohibit driving under heavy rain, snow, road ice, water, wet dirt road and other bad conditions;
- 10、 Prohibit driving in the case of the low visibility.